

LENOX BRUSHED GOLD TONE COMMERCIAL AUTOMATIC SENSOR FAUCET SPECS

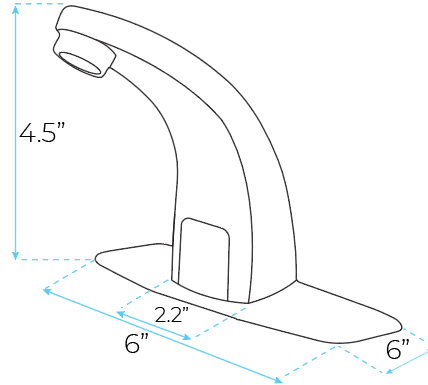

Product Details

- Durable Vandal-Resistant Brass Body; Ideal for Residential as well as commercial high use applications
- Intelligent: with its micro-computer controlling its action, the faucet will self-adjust its best detection zone as per the color and shape of lavatory
- Flashing light indicator; a diagnostic indicators for power up, low battery, and solenoid function.
- Meaning of the codes are described in the installation instructions.
- Convenient to maintain; with built-in strainer to prevent sundries from entering the solenoid valve and the strainer is easy to clean

Other Details

[Product Details](#)

Specs:

Power: DC:6V(4AA alkaline battery)
AC:220V-240V; 50/60HZ
Water Consumption: 0.05Mpa-0.6Mpa
Detection Zone: 16-32 cm or adjustable
Motor valve lifespan: up to 500000 flushes
Battery lifespan: 100000 cycles
Static Power Consumption: 0.36mw
Working Power consumption: 0.5mw
Inductive Opening Time: < 1 second
Inductive Closing Time: < 2 second
Dia.of inlet / outlet pipe: G1/2"
Flux: $\geq 0.07\text{L/S}$
Temperature: 0.1-50°C
Water Pressure: 0.05Mpa - 0.7Mpa